

★ Drill Door Holes 79,G2XX(E,M)-65

Use a drill bit to make whole holes for lock in specified location as figure 1 for Right handed door. The unmarked size tolerance of door drilling base on GB/T12341-1990-level 2. The door cut-out dimension of left handed door is same as the right-handed door's, but the mortis cut-out dimension is on the left side.

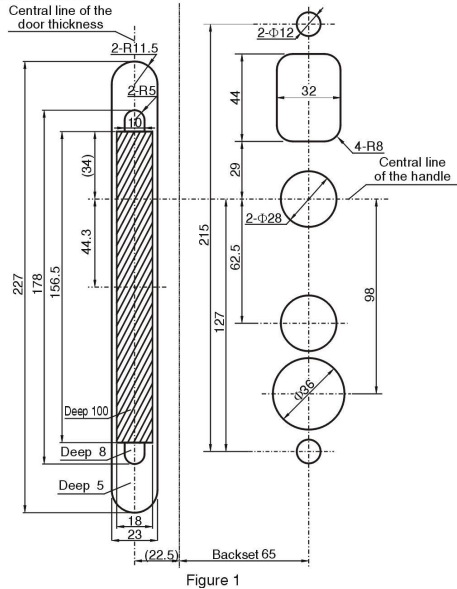

Figure 1

★ Strike box installation hole diagram

Use a drill bit to make a hole for strike box in specified location as figure 2. The height of the hole base on centerline of handle. The position of strike box should be arranged in order to make the lock keeps flush with doorframe when the door is closed.

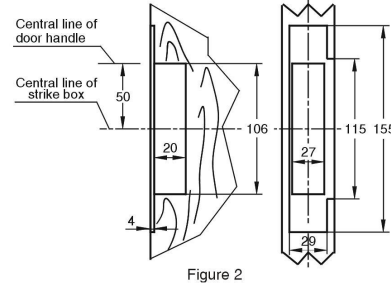

Figure 2

Put strike box into hole and fix it on doorframe with 2 screws as figure 3.

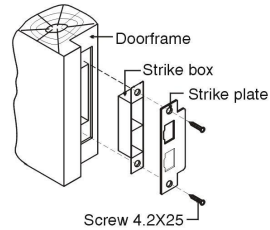

Figure 3

★ Installation Guide 79,G2XX(E,M)-65

Note: The appearance of lock in the picture may not be the same as the real model, but the installation is correct.

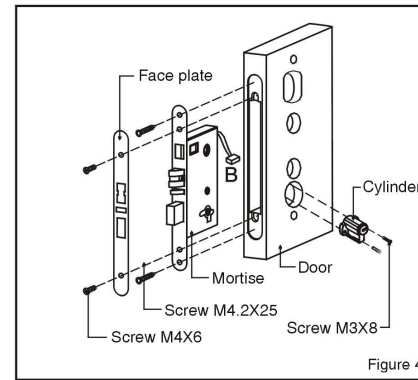

Figure 4

Install the door lock with following steps:

(1). As figure 4 shown, pull the lead-wire B through the hole on the door and fix the mortise with 2 pieces of screw M4.2X25. Cover the face plate on it and fasten it with 2 pieces of screw M4X6.

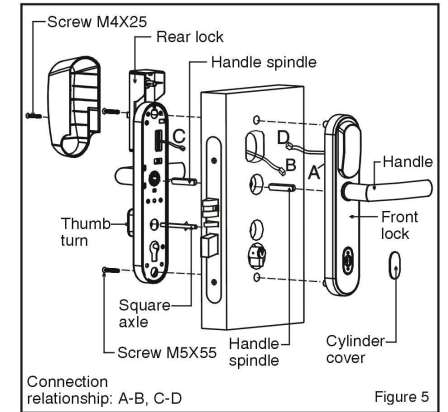

Figure 5

(2). As figure 5 shown, insert the lead-wire B into the socket A through the door hole and connect the wire C with wire D. Then insert the two handle spindles into the square holes on the rear lock and front lock respectively. And insert square axle into the square hole on the rear panel. Make sure the handle spindle and the square axle are installed on the right position. Then fasten the front lock and the rear lock with 2 pieces of pentagon screw M5X55; and use the screw M4X25 to fix the battery case cover.

Note: Before fasten the lock, make sure the lock has been initialized.

The unmarked size tolerance of door drilling according to GB /T12471-1990-level 2.