

335mm

★ Note: drill the circle 1 hole from inside when left hand door;
drill the circle 2 hole from inside when right hand door.

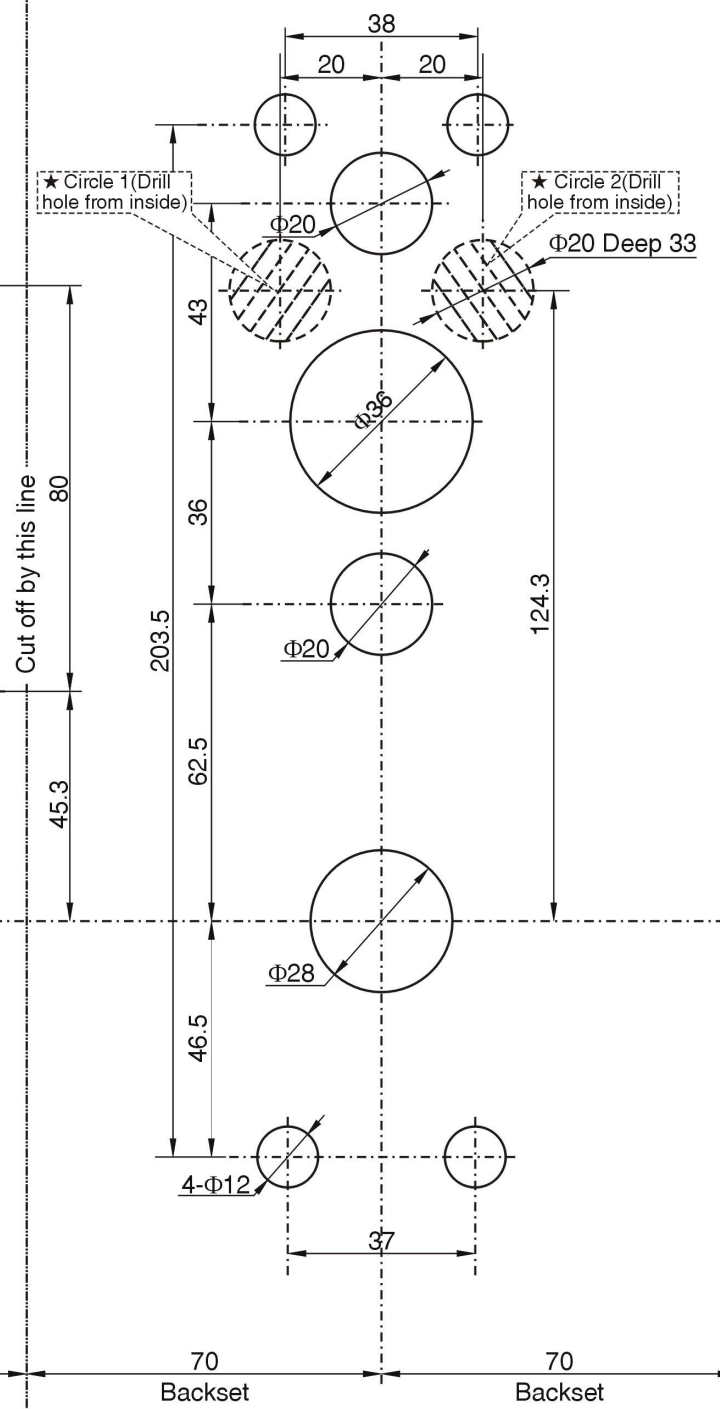
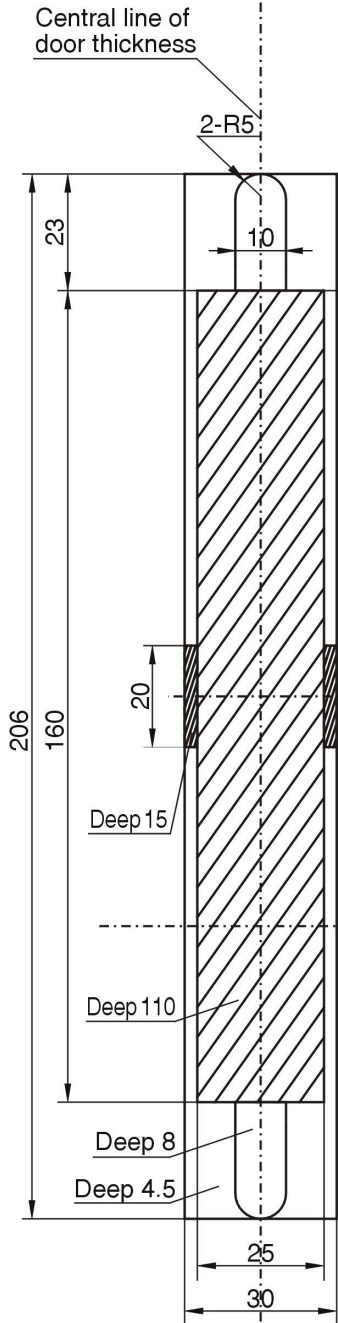

Drilling diagram

【G0,G1XX(E,M)-08】

Attention: If your door thickness is not standard (45mm), please cut off the drilling diagram by imaginary line/dotted line, then aim at the central line of your specific door thickness and make hole for installation. The unmarked size tolerance of door drilling according to GB/T12471-1990-level 2.

Scale: 1:1

Unit: (mm)

Strike box drilling hole diagram

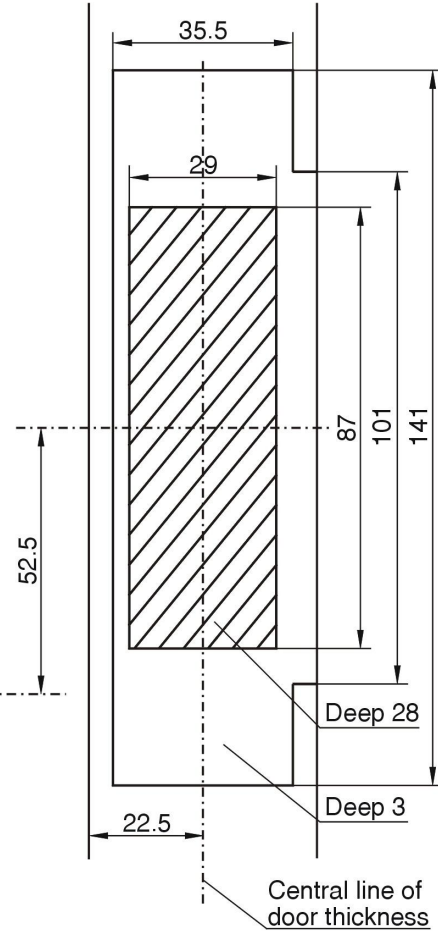

300mm